



Technocraft Industries (India) Ltd.

Titeseal Closure Product Data Sheet

50 mm and 20mm Nylon Plug With Various Gaskets

General Information

- *Manufactured in compliance with ISO-15750-3*
- *Threads comply with ISO-228*
- *Raw Material : Nylon*
- *Nylon Plugs are designed for FM requirements of safety in case of accidental fire. They bear FM stamp. To learn of its requirements refer FM Approvals Draft Standards for Plastic Bung closures for steel drum (Class number 6083) or [click here](#) for inquiries.*

Closure is available with any of following standard Technocraft gaskets. Special formulations available on request. (To know about chemical compatibility for special products [click here](#) or send email or contact postally.)

- **Black Nitrile Gasket :** *Black Nitrile Rubber (NBR) is resistant to petroleum Oils, Aromatic Hydrocarbons, Mineral Oils, Vegetable Oils and many Acids. Black Nitrile has excellent sealing properties.*
- **EPDM Gasket :** *EPDM is a multi-purpose sealing material with good and excellent chemical properties. EPDM is FDA compliant. As plug gasket, it is not recommended for application involving petroleum derivatives.*
- **Square Poly Irradiated gasket :** *Improved heat resistance due to nature of Polythelene (PE) the washers are subject to "Cold Flow" and as such to loss of compression / closing torque.*
- **Round Poly Irradiated gasket (For 2" Plug only) :** *Improved heat resistance due to nature of Polythelene (PE) the washers are subject to "Cold Flow" and as such to loss of compression / closing torque.*

Item Code

50mm Plugs with
Black Buna – 2TNPB
EPDM – 2TNPE
Round Poly Irradiated – 2TNPRI
Square Poly irradiated – 2TNPI

20mm Plugs with
Black Buna – 3TNPB
EPDM – 3TNPE
Square Poly Irradiated – 3TNPI



Advantages

- FM Approved
- ISO thread specified
- Nylon plugs are safe to use for inflammable chemicals and afford leakproofness along with chemical compatibility due to selection possible out of a variety of elastomeric gaskets.

Torque Information

Washer Type	¾" Closure		2" Closure	
	ftlbs	Nm	Ftlbs	Nm
Black Nitrile	8 – 12	11 – 16	10 – 15	14 – 20
White EPDM	8 – 12	11 – 16	10 – 15	14 – 20
Round Poly Irradiated	-	-	10 – 15	14 – 20
Square Poly irradiated	8 – 12	11 – 16	10 – 15	14 – 20

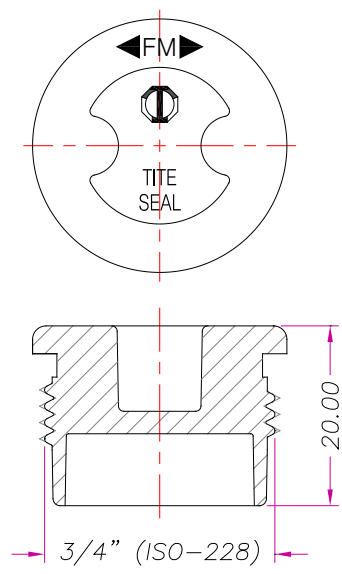
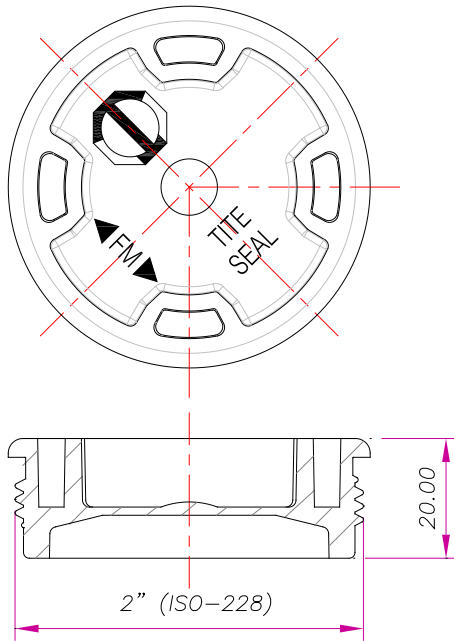

Standard Packing

Item	Box Quantity	Box Size (mm)	Pallet Quantity	Pallet Size (inch)
50mm Plug	500	525 x 345 x 250	12000	44" x 44"
20mm Plug	1000	360 x 360 x 135	54000	44" x 44"

- Boxes are marked with item code.
- Pallets are stretch wrapped.
- Optional Special packaging as per customer's requirement.

- More information can be availed by [clicking here](#) or by contacting our head quarters as per details on our web page.
- The raw material used confirms to the standard for Restriction Of hazardous Materials.